

PROTECH[®] Zoom Remote Controller AS-520 Operation Instructions

Thank you to use AS-520.

Before operating your AS-520, please read this manual thoroughly and remain it for future reference.

■ Features

- Supports the CANON Lens and FUJINON Lens with the 8-pin control interface for a ENG video camera for the professional use.
- Selectable for CANON Lens use or FUJINON Lens use.
- Selectable zooming speed, SLOW and FAST. At SLOW position it takes approximately twice time to zoom from WIDE to TELE or reverse as at FAST position.
- Able to change the RETURN and VTR trigger functions of the RET/REC button and REC/RET button.

■ Outsideview and Dimensions/Parts Names and Functions

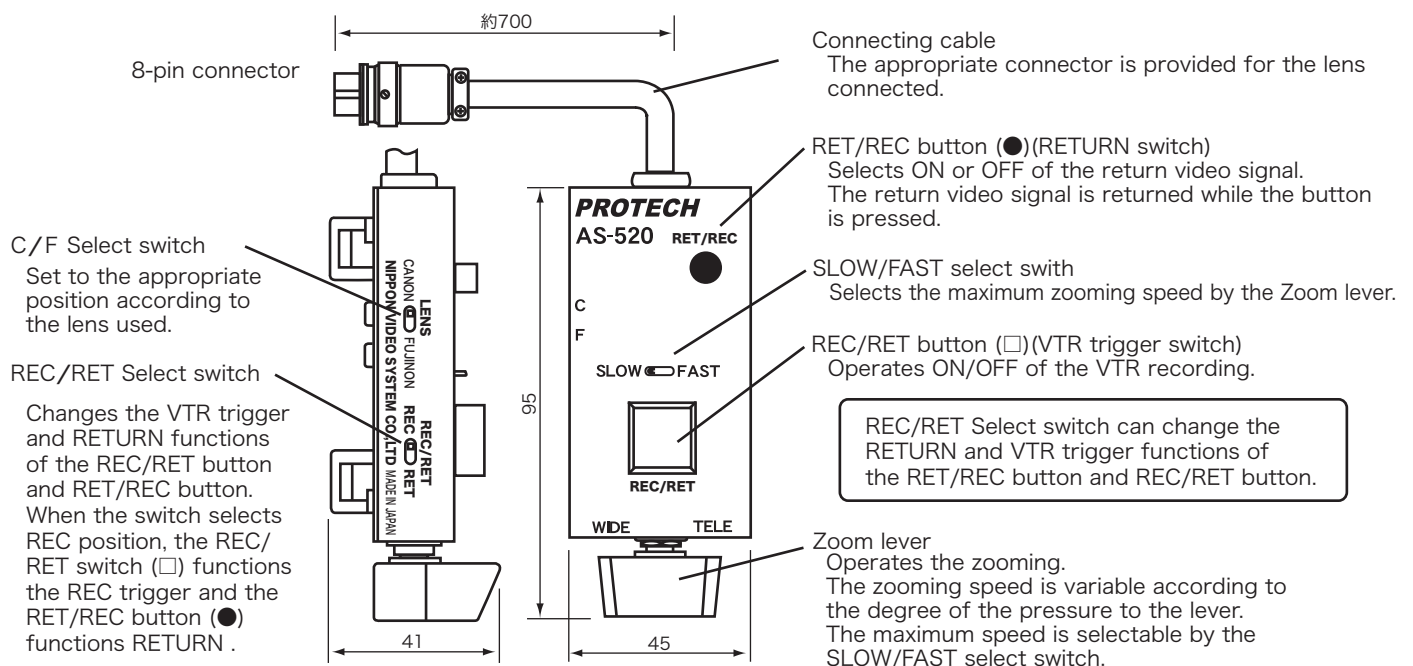

■ Installation

1. Fasten AS-520 to the pan handle of the tripod by the supplied Repeat Bands.
2. Connect the 8-pin connector to the camera lens.
3. Set the switches to the appropriate position.

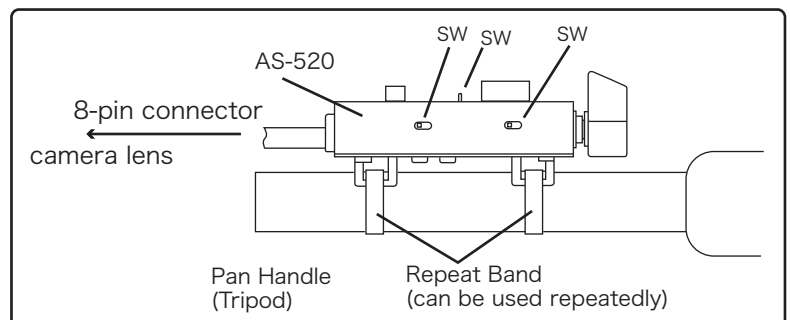

■ Specifications

Supported Lens	CANON Lens, FUJINON Lens	C/F SW	CANON or FUJINON Selection
REC SW	VTR REC Start/Stop	RET/REC SW	RET/REC Selection
RET SW	Video signal returns while the button is pressed.	Outside dimensions	45 × 95 × 41 mm (W×H×D)
SLOW/FAST SW	Zooming speed, SLOW/FAST	Weight	approx. 215 g
Accessories	Repeat Band(to fasten to the pann rod)/Operating Instructions		

NOTE Features, design and specifications are subject to change without notice.