

Thank you to use FD-300A this time.
Please read this operation manual before using it.

■ Main Features

Simultaneous communication among several sets of FD-300A is available.

BNC cable for video signal can be used. Special cable is not necessary.

Microphone and headphone can be adjusted independently.

Dry cell battery (006P type) and external power can be used.

It can be connected with FD-800S (Intercom Station).

■ Operation Instructions

Connect each FD-300A with BNC cables. Put the supplied dry cell battery to inside. Next, turn up the volume of the headset and microphone gradually. If howling occurs, turn down the volume of the microphone first. If howling continues, turn down the volume of the headset. When several sets are connected, howling may occur even if the volume of 1 set is turned up much. Turn up the volume of each set according to the increase of the distance and number of the set.

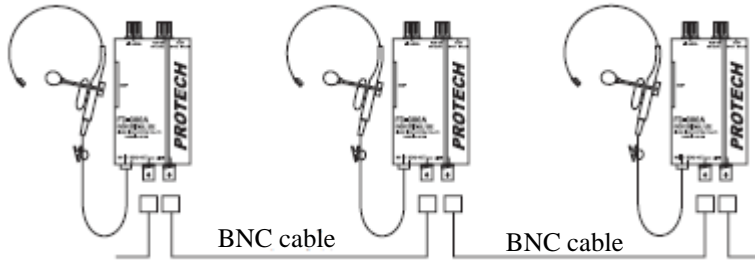

Maximum 10 sets of FD-300A can be used.
BNC cables can be used up to 2km as total length.

■ Composition of the set

FD-300A, headset, dry battery cell (9V 006P) x1, attachment hardware for Sony camera, screw 2 type x2

■ Dimension and name of each part

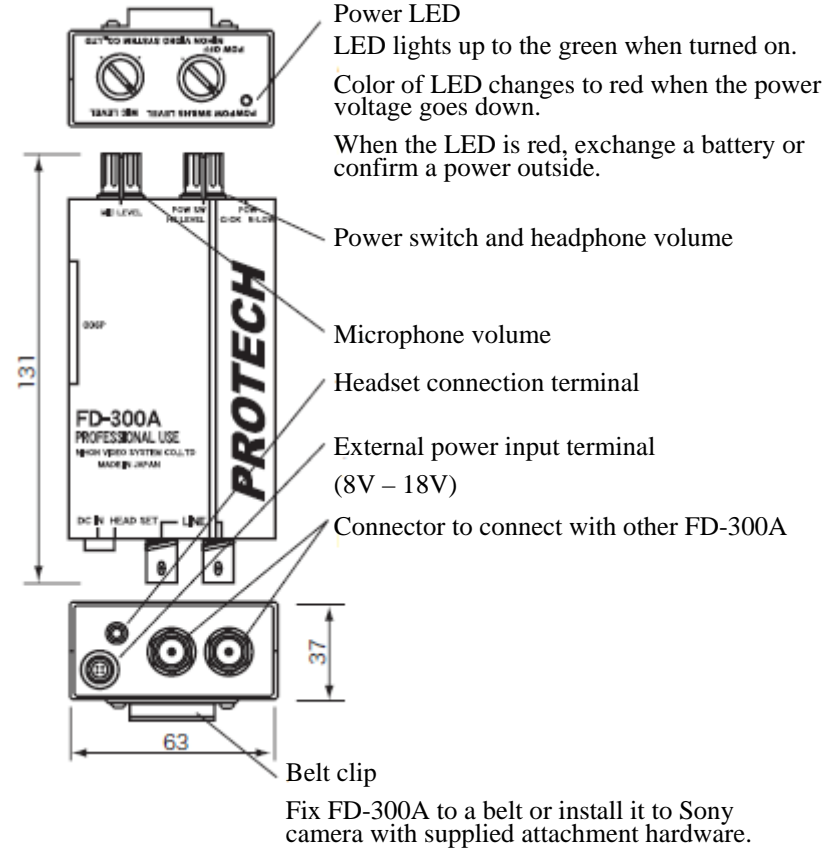

■ Option

- TD-200 Talk switch (Communication is possible when pushing)
- TD-300 Talk switch + mini 4pin power cable
- TA-300 Sony camera attachment (Metal hardware may be need in some cases)
- BNC-10M BNC-BNC 10m cable
- BNC-30M BNC-BNC 30m cable
- BNC-100M BNC-BNC 100m cable

FD-300A Specifications

Function	System	BNC 2-wire Intercom
	Line Impedance	22 ohms
	Transmitting distance	Max. 2Km
	Adjustment	Mic. Level, Headphone level
	In/Out connector	Line: BNC connector x2
		Headset: 3.5Φ mini-jack
	Headset	Remote/External power supply: mini 4pin
Power	Power consumption	Approx. 0.09W
	Power supply	Internal 9V 006P x1, External DC 8 - 18V
General	Using temperature	0°C - 40°C
	Storage temperature	-20°C - 60°C
	Weight	Approx 260g
	Size	63 x 37 x 131mm (WxHxD)
Option	TD-200	Talk switch (It is possible to talk while pushing)
	TD-300	Talk switch + mini 4pin power cable
	TA-300	Sony camera attachment (It is necessary by the case)
	BNC-10M	BNC-BNC 10m cable
	BNC-30M	BNC-BNC 30m cable
	BNC-100M	BNC-BNC 100m cable
Accessory	Headset, 9V 006P x1, Sony camera installation hardware, Screw 2 type x2 per each	



Attention on safety

Please guard.



The case where it is used by professional
Tec commodity common optional AC is contained.

It explains the guard without fail to prevent the damage to harm
and the property to the person and other people who use it beforehand as follows.

- It divides in the following table, and it explains the level of harm and the damage caused when a usage wrong as the content of the display is disregarded is done.







	Warning	The column of this display is "The possibility of owing the death or the serious injury, etc. is assumed" content.
	Attention	The column of this display is "The possibility that only the possibility or the physical loss or damage in which the trouble is owed occurs is assumed" content

- It divides by the following picture display, and it explains the kind of the guarded content.
(The following are one picture display example.)

	Such a picture display is an attentive "Attention rousing" content that wants to hold.
	Such a picture display is "Prohibition" content that cannot be done.
	Such a picture display is "Compulsion" content executed without fail.

About use







 Warning

 <p>Neither a container where water entered on this machine nor a small metallic thing are put.</p> <p>Prohibition</p>	 <p>The foreign body is not inserted, and not dropped from the opening of the equipment.</p> <p>Prohibition</p>	 <p>This machine is not remodeled.</p> <p>Resolution prohibition</p>
 <p>It doesn't use it in the water place.</p> <p>Water place use prohibition</p>	 <p>Neither the back cap, the cabinet nor the cover, etc. of this machine are removed.</p> <p>Resolution prohibition</p>	 <p>It is done to wet the equipment and watertight.</p> <p>Prohibition</p>

About use

 Attention

About maintenance

 <p>A heavy thing is not put on this machine.</p> <p>Prohibition</p>	 <p>It doesn't take this machine.</p> <p>Prohibition</p>	 <p>When maintaining it, the switch is turned off for safety.</p> <p>The power supply is pulled out.</p>
 <p>When not using it, the power supply is pulled out for safety.</p> <p>The power supply is pulled out.</p>	 <p>The power supply is pulled out, and an external code is removed when moving.</p> <p>The power supply is pulled out.</p>	 <p>The consultation of an internal cleaning is : to the shop about once a year.</p> <p>Compulsion</p>